



Model NO. C10B

Consumer mini booster

Wide band in any system of CDMA, GSM, DCS, WCDMA, PCS

Introduction



- ▶ The consumer repeater from Amplitec is an ideal solution for providing a cost effective improvement in cellular in-building coverage up to 100~300 Square meters, such as a home, office, restaurant or building, in the quickest time possible, on any of CDMA, GSM850, GSM900, GSM1800, GSM1900, and WCDMA.
- ▶ Wide band feature enables all devices operating within the wide frequency range of the repeater to see an improvement in performance.
- ▶ Multiple phones and other handheld devices throughout a building can benefit from a wireless repeater.
- ▶ Supports up to (30) users / calls simultaneously.
- ▶ Extended phone battery life. (Your phone does not need to put out as much power due to improved reception.)
- ▶ No more running outside or near windows to complete your calls or receive pages.

Block Diagram

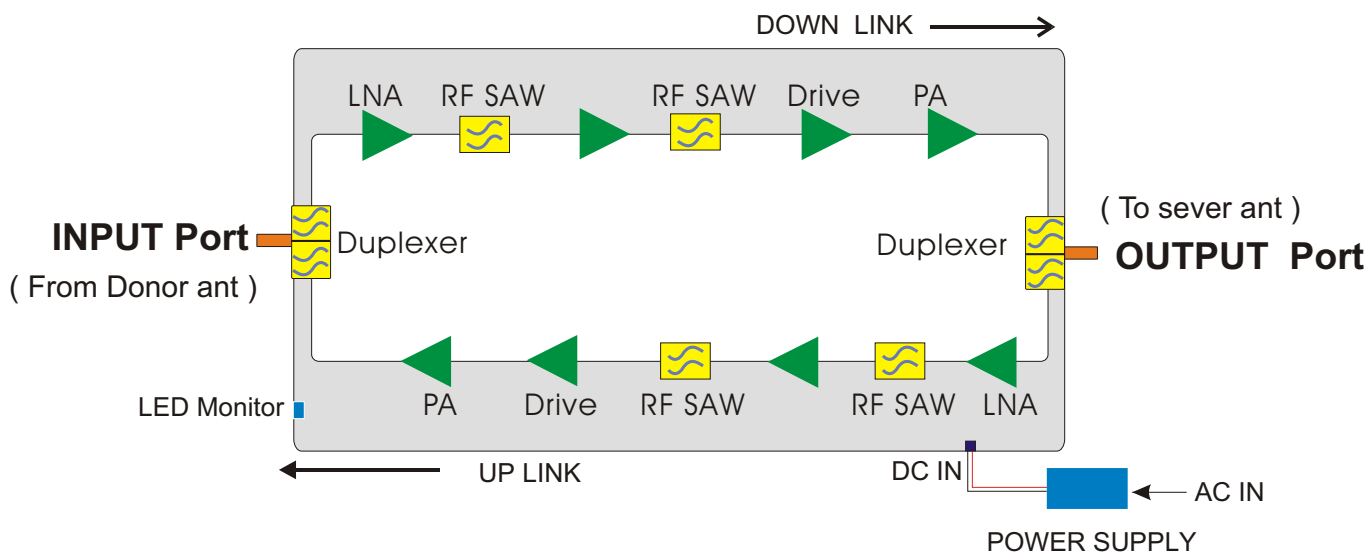

Amplitec Corporation

Add: 2F, No. 40, Tonghuadongyi Road, Chancheng Dist., Foshan, Guangdong, P.R.China
 Tel: (86)757-83308393/83308238 Fax: (86)757-83123923
 Email: info@amplitec.cn Website: www.amplitec.cn



Http://www.amplitec.cn

Model NO. C10B

Consumer mini booster

Wide band in any system of CDMA, GSM, DCS, WCDMA, PCS

> Specification

Electrical Specification

Frequency Range		
CDMA	UL:824~849MHz	DL:869~894MHz
GSM850	UL:824~849MHz	DL:869~894MHz
GSM	UL:890~915MHz	DL:935~960MHz
DCS-L	UL:1710~1775MHz	DL:1805~1870MHz
DCS-H	UL:1720~1785MHz	DL:1815~1880MHz
PCS-L	UL:1850~1900MHz	DL:1930~1980MHz
PCS-H	UL:1860~1910MHz	DL:1940~1990MHz
WCDMA	UL:1920~1980MHz	DL:2110~2170MHz
Bandwidth	Wide band	
Maximum Gain	≥ 50dB	
Output Power	≥10dBm	
Spurious Emission	≤ -36dBm (9KHz~1GHz)	
	≤ -30dBm (1GHz~12.75GHz)	
Noise Figure	≤ 6dB (Typical)	
Group Delay	≤ 1.5uS	

Mechanical Specification

I/O Port	N-Female
Impedance	50 ohm
Dimensions (W x H x D)	120x93x24mm
Weight	≤ 700g
Operating Temperature	-10°C~50°C
Environment Conditions	IP40
Switch Adapter	Input AC 90~265V, Output DC 9V/2A

Application <

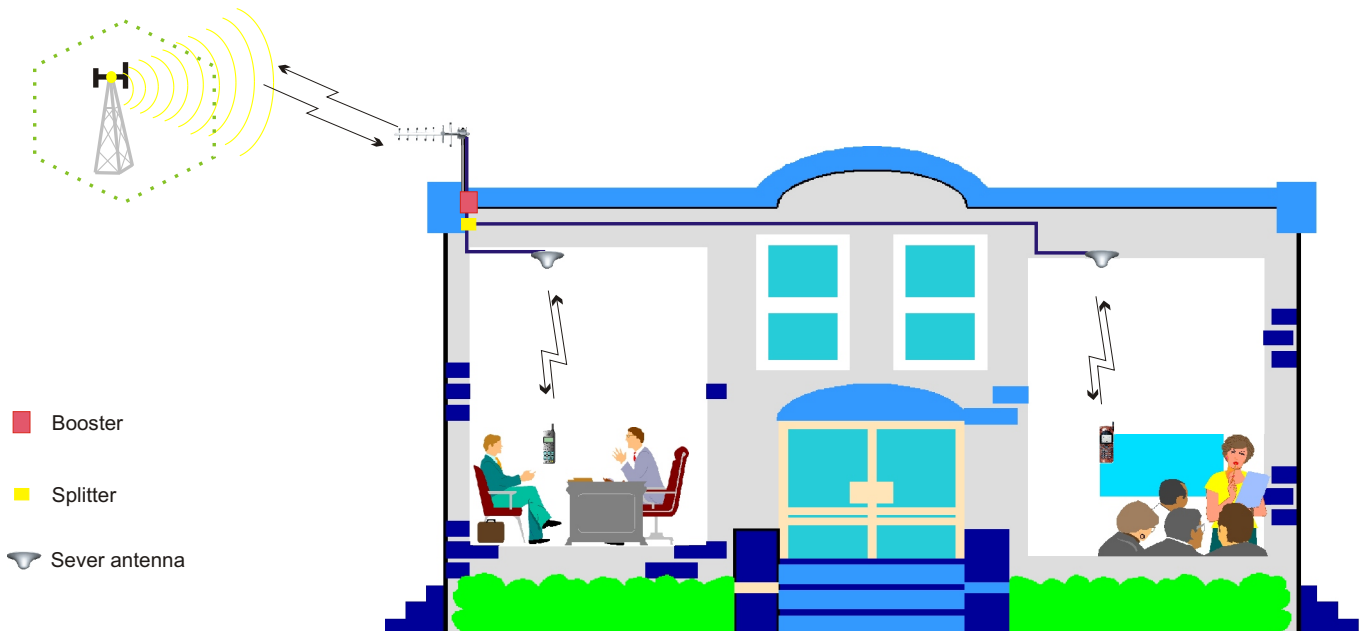

Amplitec Corporation

Add: 2F, No. 40, Tonghuadongyi Road, Chancheng Dist., Foshan, Guangdong, P.R.China

Tel: (86)757-83308393/83308238

Fax: (86)757-83123923

Email: info@amplitec.cn

Website: www.amplitec.cn