

## Quick Installation Guide

- **Ports:**

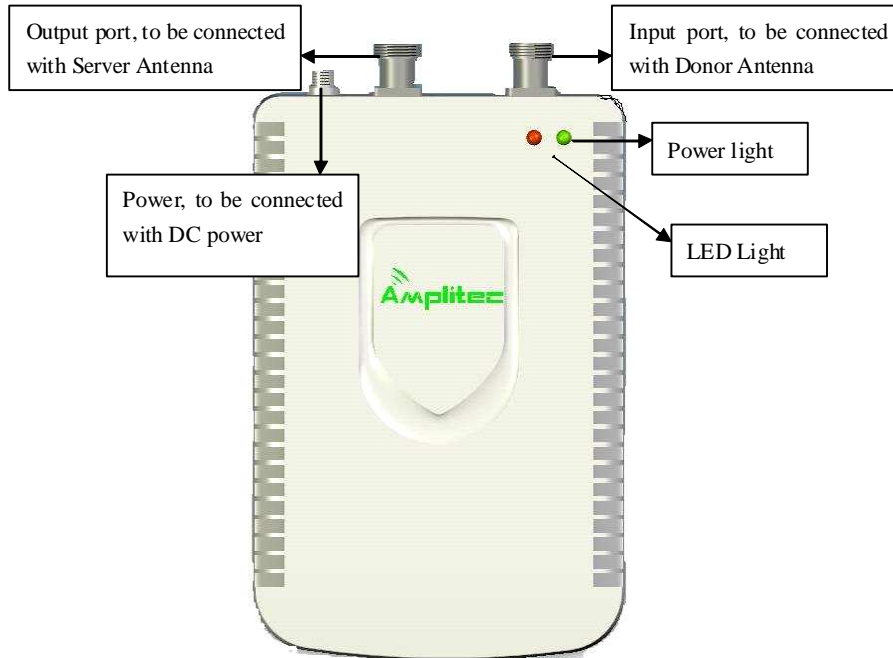

- **Installation Requirements**

C20 series repeaters are mainly applied as indoor coverage system. After connection of equipment and antenna, the distance of them should be keep as far away as possible, it's better that there is a wall as the obstruct between them.

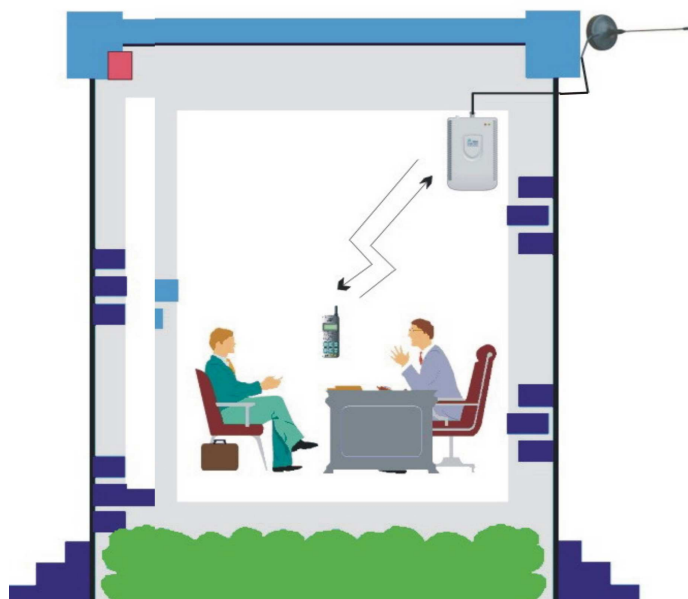

### ■ Position selection

- Install in the place that is not easy to be reached by irrelevant people.
- Install at the place that is convenient for power supply and cabling
- Avoid heat source and moist environment

### ■ Power supply requirement

AC power supply of 85~265VAC

## ● Installation Sketch and Steps

### ■ Installation Sketch

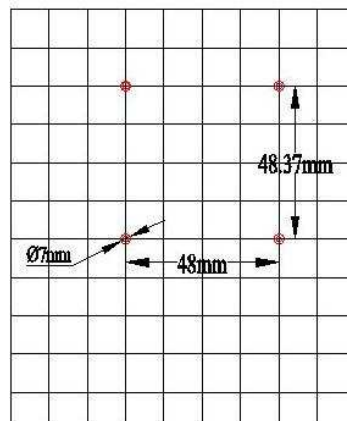

### ■ Installation Step

- 1: Use percussion drill to make four  $\Phi 7$  holes on the wall according to above hole diagram, fasten component 1 onto the wall.
- 2: Fasten component 2 onto the equipment
- 3: Put the component 2 into component 1

### Step 1

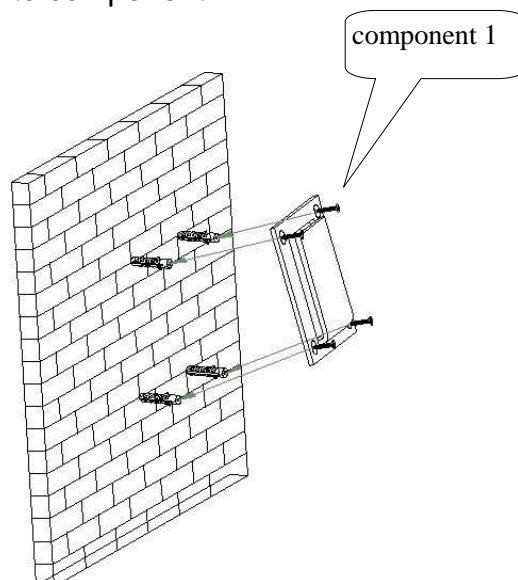

### Step 2

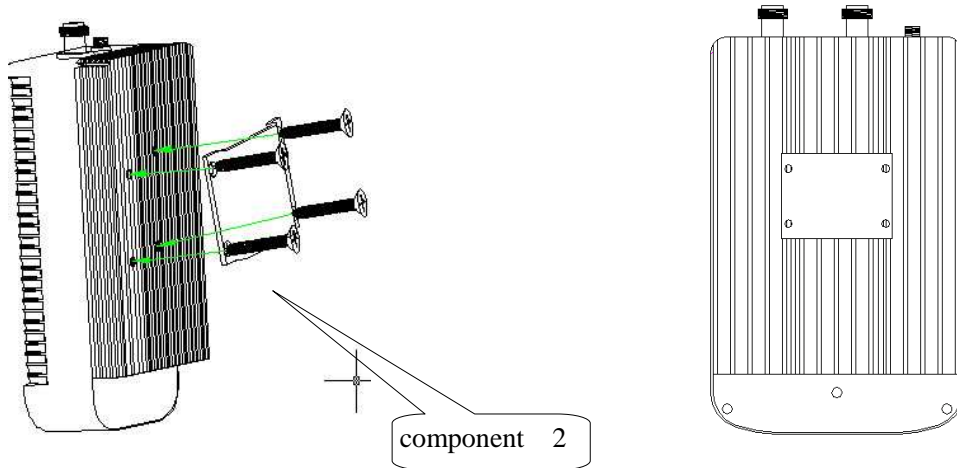

### Step 3

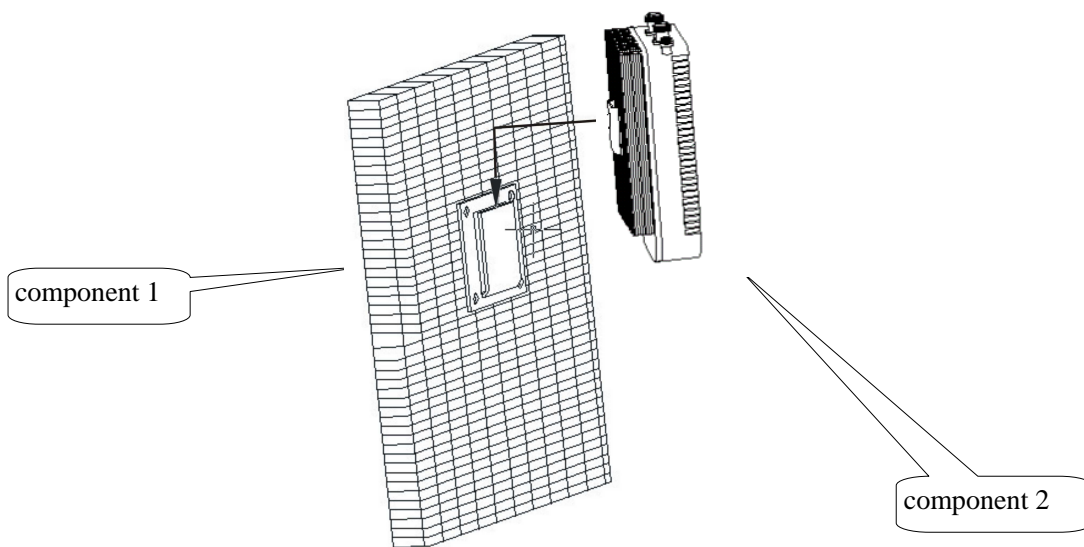

## ● Connection

### ■ Connection of RF cable

Input Port: put the antenna outdoor, and try to put on the place where there is strong signal, then connect one adapter to BTS of equipment and assure good connection.

### ■ Power supply connection

Please use three-legged plug to assure good grounding