



Foshan Amplitec Tech Development Co., Ltd No.1 Room, Second Floor, No.40, First East TongHua Rd, FoShan 528000, China
 Tel: (86)757-83308238 Fax: (86)757-83123923
 Website: <http://www.amplitec.cn>

AMP-0825DSAL

Full Band Waterproof Antenna

Technical Specification

Features

- Support all main telecommunication
- Wide band working frequency 800MHz~2500MHz system currently
- Low VSWR
- Nice cover mask, good protection
- Match with adjustable clincher, flexible for wall-mounting or Pole-holding installation

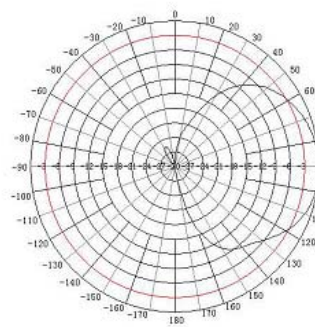

E SIDE

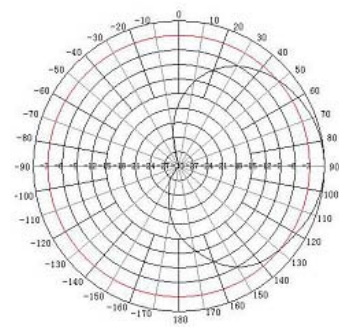

H SIDE

The picture is for reference only, the actual item is the standard.

Technical Specification

Module	AMP-0825DSAL
Frequency Range-- MHz	800-960 / 1710-2500
Horizontal Beamwidth--°	60 55
Vertical Beamwidth--°	90 70
Front to Back Ratio-- dB	18
Gain -- dBi	8.2 9.5
VSWR	≤1.5
Input Impedance --Ω	50
Polarization	Vertical
Max.Power --W	100
Connector Type	N-Female or upon request
Dimension(without clincher) --mm	293*210*65
Weight (with clincher) -- kg	0.92
Standing Pole diameter—mm	Ø40-Ø50

Installation

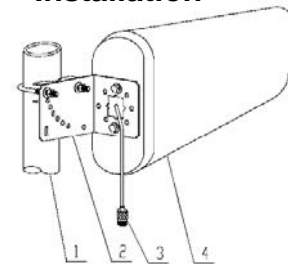

Pole holding installation

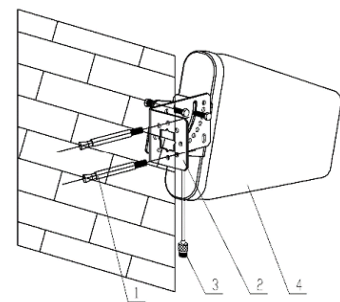

Wall mounting installation

- 1 Pole or screws (self-prepared)
 2 L type clincher 3connector 4product

Notice: When installation, the penal side with tiny hole should face down to avoid water going in.